

ELECTROPHILE[®]

(I N D I A) P R I V A T E L I M I T E D

ENGINEERING SHINES THROUGH



ABOUT US

We are one of the prominent Govt. approved 'A' Class contractor engaged in providing services for **engineering, installation, testing and commissioning of electrical projects**. Our services are effective and executed as per the requirement of our clients. Our organization also has **11 KV *A* Class Electrical Contractor license** from the Government of Haryana and NCT Delhi. Moreover, we undertake turnkey basic, electrical and illumination contracts of HT / LT equipment.

We ourselves are **Manufacturers of Electrical Equipments like Distribution Boards, On Load Changeover Switches, MCBs, Canopies for Busbar Trunking system.**

We are also renowned distributors and stockiest for some of the leading brands of the country. Moreover, our organization has tied up as authorized partners through its associate concern with renowned switchgear, control gear and automation product manufacturers. The company is one of the leading source points for procurements for timely deliveries.

MISSION

- Build the best product.
- Use business to inspire and innovate new technologies.
- To create a world class working environment for the employees of our company.
- To save the interest of the society and nature by reducing carbon emissions.

VISION

- Our vision is to be world's most reputed firm and to be customer centric to fulfill all its need by giving best quality products.



INFRASTRUCTURE

Stable business infrastructure ensures the proper coordination of all human resources, processes and other operational tools necessary to ensure manageable, profitable growth. This is especially important during unexpected growth spurts.

A company has to maintain it because without proper machinery and tools, the production comes to a halt. We have installed best in class machines for manufacturing procedures from the world renowned brands of latest technologies.

- CNC Turret Punch Press from AMADA(AE2510NT)
- HACO Shearing Machine
- HACO Bending Machine
- MIG and Arc Welding Equipments
- Well equipped Powder Coating Process



PRODUCTS

DISTRIBUTION BOARDS

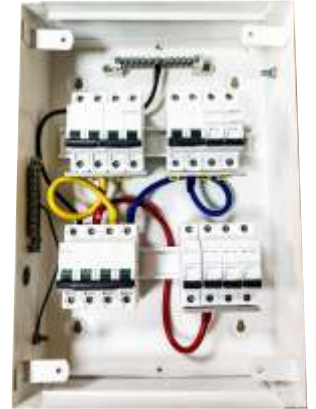

No. of Ways
(SPN)

Catalogue No.

4 Way

EIPL-4SPN

6 Way

EIPL-6SPN

8 Way

EIPL-8SPN

10 Way

EIPL-10SPN

12 Way

EIPL-12SPN

No. of Ways
(TPN)

Catalogue No.

4 Way

EIPL-4TPN

6 Way

EIPL-6TPN

8 Way

EIPL-8TPN

10 Way

EIPL-10TPN

12 Way

EIPL-12TPN

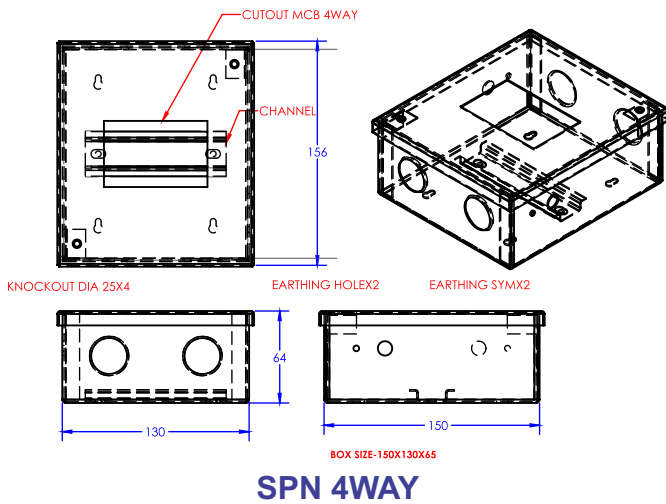

SPECIFICATIONS :

Material: Mild Steel

Frequency: 50Hz

Colour Code:RAL 9010

Scratch Resistant, Glossy surface

Compact DB which require minimum space.

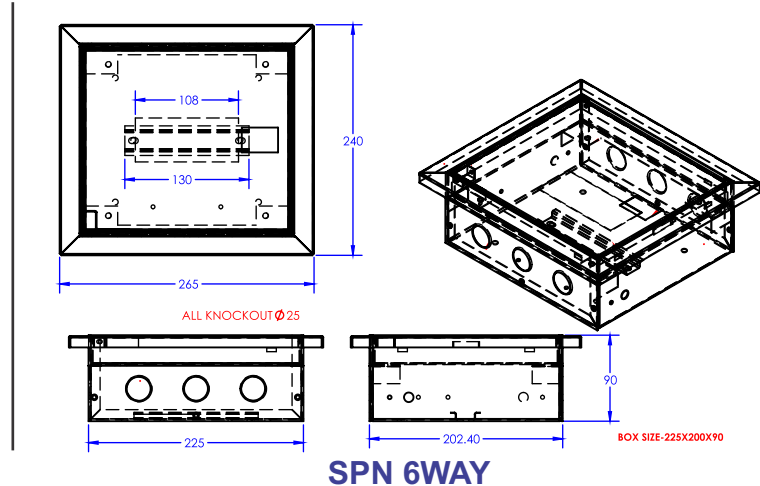
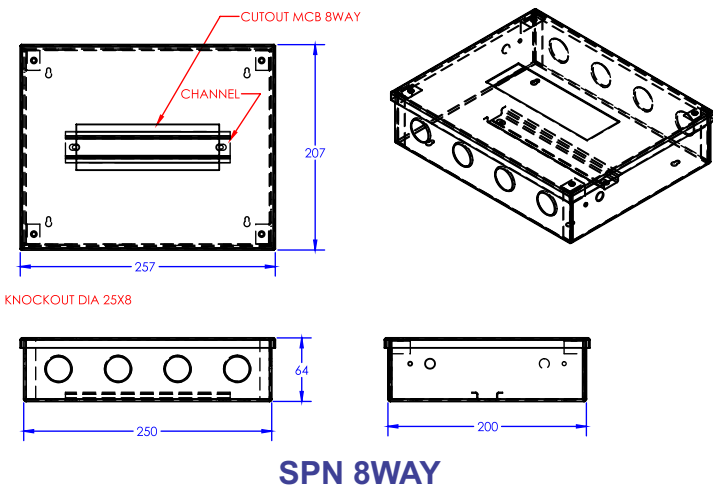

VERTICAL DISTRIBUTION BOARDS

No. of Ways	Catalogue No.
4 Way	EIPL-4VDB
6 Way	EIPL-6VDB
8 Way	EIPL-8VDB
10 Way	EIPL-10VDB

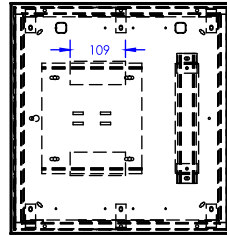
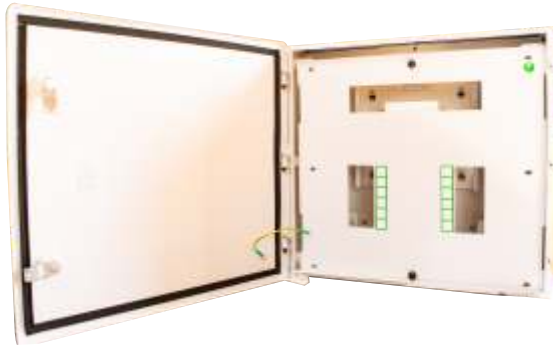

6 WAY-VERTICAL-DB

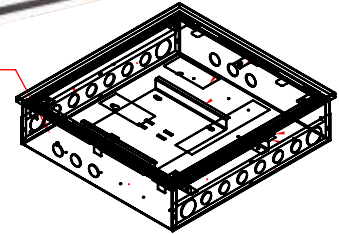

FOR EARTHING

ALL KNOCKOUT-Ø25

KNOCKOUT-Ø38

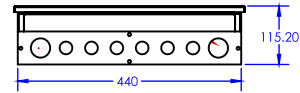
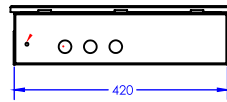

CHANGEOVER SWITCHES



Rating	Phase	Catalogue No.
16A	Single	C1-16
25A	Single	C1-25
32A	Single	C1-32
63A	Single/Three	C1/3-63
80A	Three	C3-80
100A	Three	C3-100
125A	Three	C3-125
160A	Three	C3-160
200A	Three	C3-200
250A	Three	C3-250
315A	Three	C3-315
400A	Three	C3-400
630A	Three	C3-630
800A	Three	C3-800
1000A	Three	C3-1000
1250A	Three	C3-1250
1600A	Three	C3-1600
2000A	Three	C3-2000
2500A	Three	C3-2500
3150A	Three	C3-3150

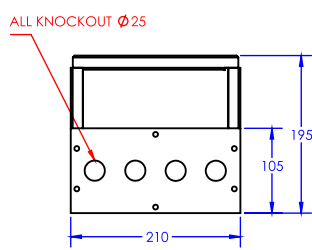
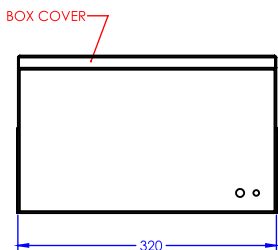
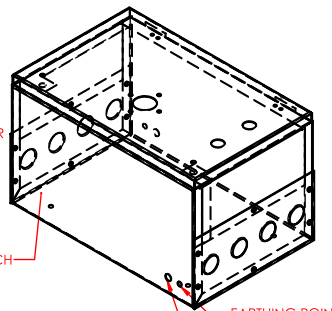
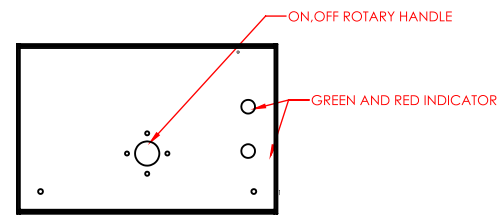

SPECIFICATIONS :

Rotary Type Switches
 IEC 60947-3
 AC-23A | U_e 415V a.c.
 UI 1000V | I_{sc}=80KA rms
 50Hz | 4 Pole

PCC & MCC PANELS

SALIENT FEATURES :

- Design tested at CPRI for short circuit & temperature rise as per IS/IEC standards.
- Computer Aided Design systems
- Panel enclosure degree of protection IP-54, IP-55 & IP65
- Anti corrosion Treatment.
- Non hygroscopic SMC busbar supports for best mechanical & electrical strengths for fault current withstand.
- Busbars and interlinks are insulated with heat shrinkable PVC sleeves.
- Provision for future expansion for both sides
- All lives parts are shrouded with polycarbonate sheets.

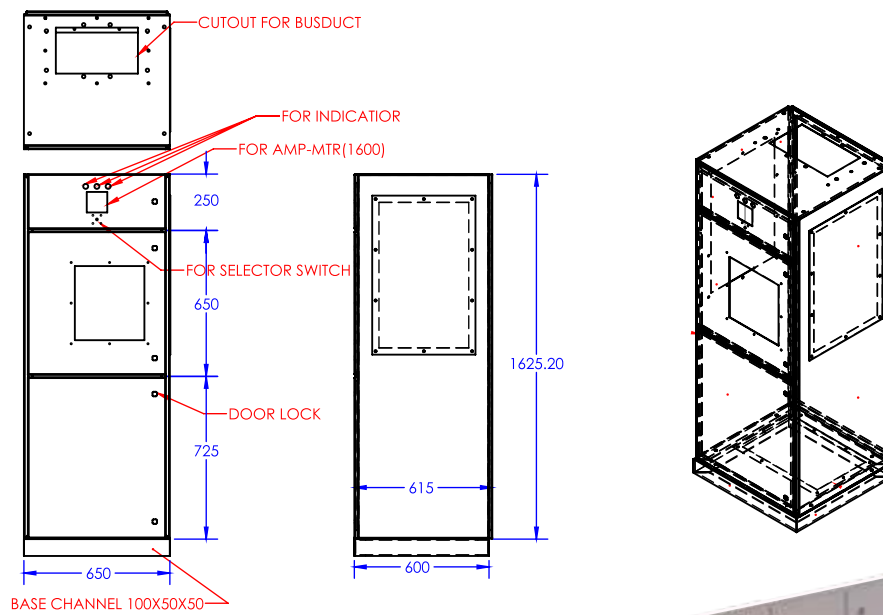

MINIATURE CIRCUIT BREAKERS

Single Pole	Double Pole	Triple Pole	Four Pole
0.5 to 5A	0.5 to 5A	0.5 to 5A	0.5 to 5A
6 to 32	6 to 32	6 to 32	6 to 32
40A	40A	40A	40A
50A	50A	63A	63A
63A	63A	100A	100A
100A	100A		

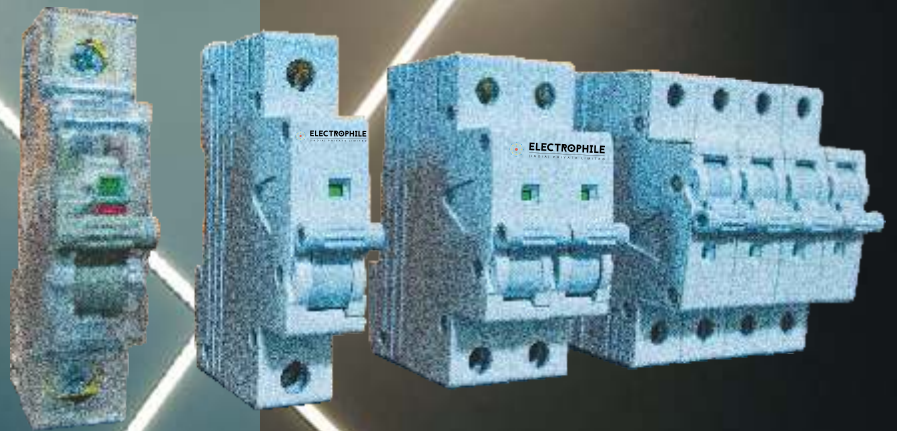

MCB TYPE CHANGEOVER

DOUBLE POLE	FOUR POLE
25A	25A
32A	32A
40A	40A
63A	63A

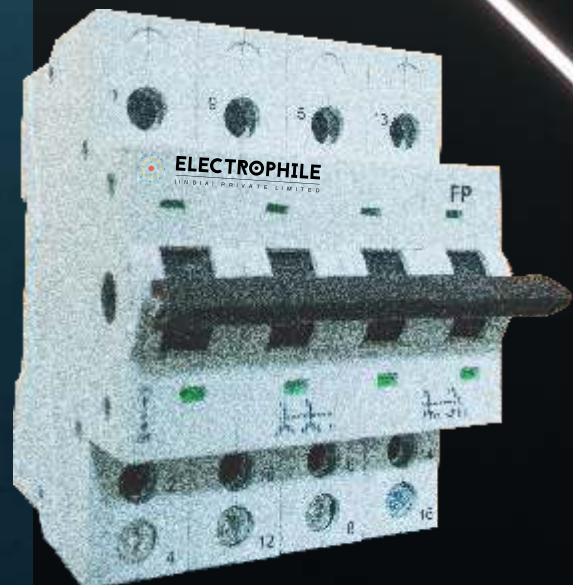

CERTIFICATIONS & APPROVALS



We are accredited with ISO 9001:2015 certification and dedicated towards quality process and management systems in order to deliver the best products with speedy and good services to our customers.

We have a well developed service network that enables us to execute projects effectively. Owing to our prompt and cost effective service, we have acquired many reputed clients across the country. Our engineers maintain close coordination with our clients, while undertaking these project works.

We are also participating and conducting activities and training programmes for our employees and have successfully implemented systems like KAIZEN, TBM, 5-Sigma.

CLIENTELE

- CPWD - Central Secretariat South Block, Delhi
Kolkata Airport
- NTPC – Giral TPP, Rajasthan
- CPWD – Parliament Library, Delhi
- Uranium Corporation of India Ltd., Jamshedpur
- J P Hydro electric Chamera Himachal
- Today Hotel, Gurgaon
- Hotel Ista, Ahmedabad
- Jai Bharat Maruti Ltd., Gurgaon
- Suzuki Powerten Ltd., Manesar
- Rico Auto Industries, Gurgaon
- New Holland Tractor, Noida

- Yakult & Doner Food Product, Sonipat
- C & S Electric Limited, Delhi Sudhir
Engineering Company
- Sudhir Power Project Pvt.Ltd. Alstom Ltd.
- Jakson Engineers Ltd.

.... And many more



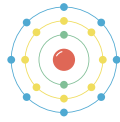

ELECTROPHILE[®]

(INDIA) PRIVATE LIMITED

Office:

Shed no 150A, Sector 31,HSIDC,
Faridabad-121003. Haryana, INDIA

Manufacturing Unit :

Plot no 31, Srisai Industrial Area, Harfala Road,
Sikri, Faridabad, 121004.

Phone: +919711444673, +919811047496

Fax: 01294062233

Email: info@electrophileindia.com,
vinay.gaur@electrophileindia.com

Website: www.electrophileindia.com

Find us on :

